



CDT 40

## CDT 40 MOBILE DEHUMIDIFIER

### Function

The CDT 40 is a robust, cost-effective and energy-efficient, reliable mobile dehumidifier. It works in accordance with the condensation principle. A fan draws the humid air into the dehumidifier and through an evaporator coil. When passing through the evaporator the air is cooled down to below its dew point temperature, and its content of water vapour is condensed into water, which is collected in the water container.

### Applications

- Damage service
- Building drying
- Water works
- Dry storing

## FEATURES

### Dehumidifier

- High capacity
- Low energy consumption
- Strong and robust cabinet of powder coated hot galvanized steel
- Epoxy coated evaporator and condenser.
- Adjustable handle
- Plastic bumpers
- Low weight
- Stackable.
- Large wheels

### Water container

- Water container with handles
- Automatic stop when water container is full or removed.
- Permanent drainage can be established with optional ½" hose connection
- Condensate pump in a cassette as optional extra

### Electronic control

- Digital touchpad control panel with display
- Accurate hour and kWh counter (reading)
- RH and °C monitoring (reading)
- RH setting
- Easy fault-finding
- Service monitoring function

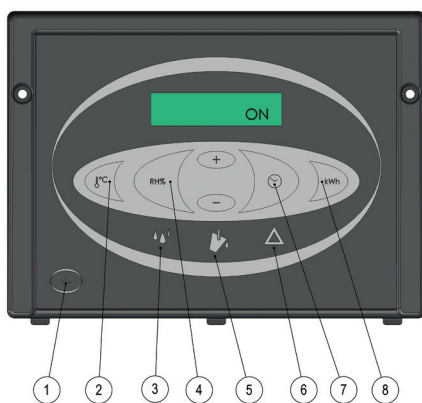

### Digital touchpad control panel:

1. On-off switch
2. Reading of room temperature
3. Indicator for normal operation (green lamp)
4. Reading of RH value / setting of RH value
5. Indicator for full water container (yellow lamp)
6. Failure indicator (red lamp)
7. Hour counter / setting of service intervals
8. kWh counter

### Defrosting

Active, demand-controlled defrosting which is activated through a temperature sensor on the evaporator. Defrosting is done by means of hot refrigerant being fed through the evaporator.



**TECHNICAL DATA**

<b>Model</b>	<b>CDT 40</b>
Operating range – humidity	40-100% RH
Operating range – temperature	3-32°C
Air volume	350 m <sup>3</sup> /h
Power supply	230 V/50 Hz
Max. ampere consumption	3,6 A
Max. power consumption	0,82 kW
Refrigerant	R 407C
Compressor type	Rotary
Sound level (at 1 metre)	59 dB(A)
Water container capacity	14 litres
Colour - water container and wheel cap	RAL 7044
Colour - front grille	RAL 7015
Colour - control panel and bumpers	RAL 9005
Protection class	IP X4
Filter	PPI 15/G1
Wheel size	Ø 250 mm
Wheel and water container material	PP
Control panel material	ABS
Weight	43 kg

**CAPACITY CURVES**

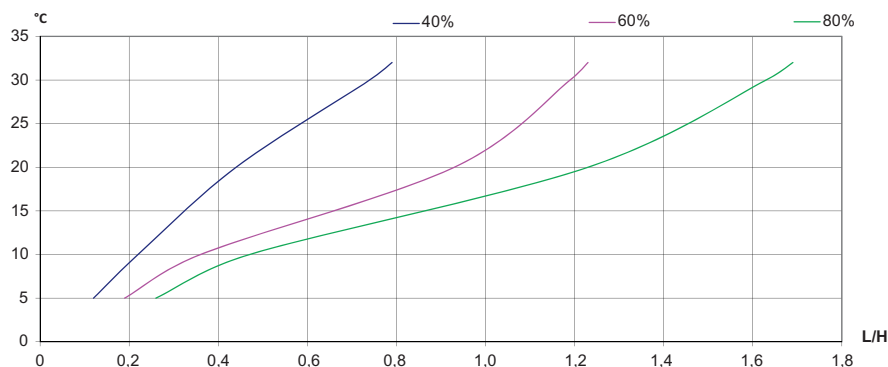

**Specific energy consumption (SEC)**

- 0,50 kWh/l at 30°C & 80% RH
- 0,66 kWh/l at 20°C & 60% RH

**Accessories**

- ½" drain outlet
- Remote hygrostat
- Wall bracket
- Dual voltage kit
- Condensate pump in a cassette (see separate data sheet)

**Also available in this series:**

- CDT 30
- CDT 30 S
- CDT 40 S
- CDT 60
- CDT 90
- (see separate data sheets)

**DIMENSIONS**

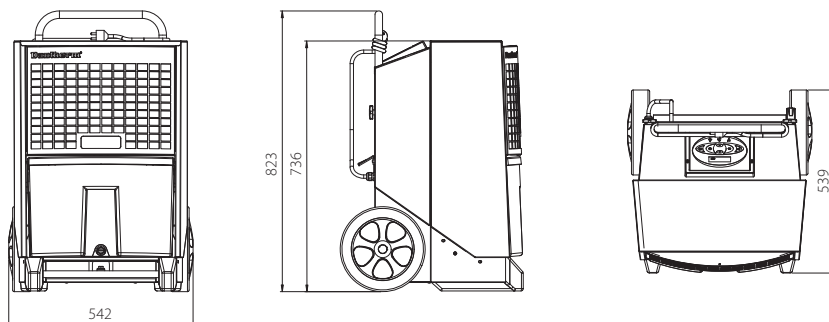

All dimensions are in mm.